

Building a House

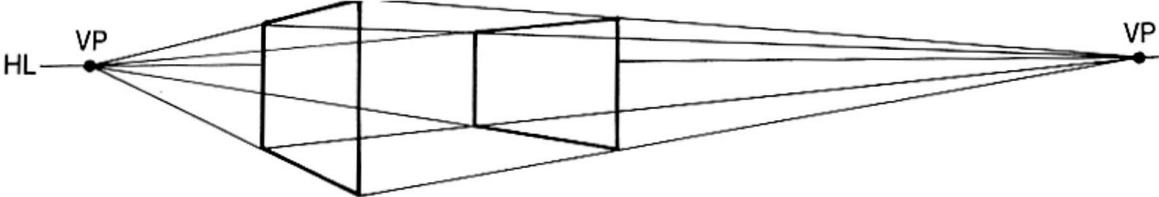

Learn the foundational principles of using 2-Point perspective to create lifelike objects

1)



To find the point of the roof, draw a line from each corner to the other. This gives us the exact center of the front and back of the house. Next, draw a vertical guideline for the true center line extending above the walls.

2)

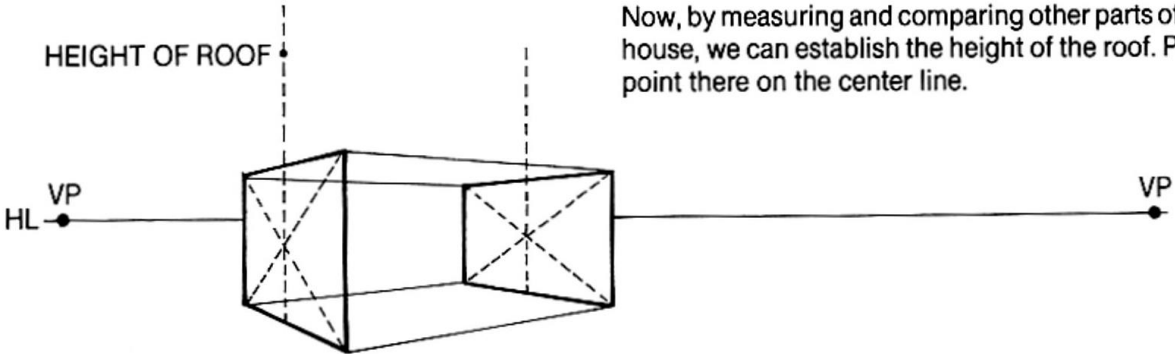

Now, by measuring and comparing other parts of the house, we can establish the height of the roof. Put a point there on the center line.

3)

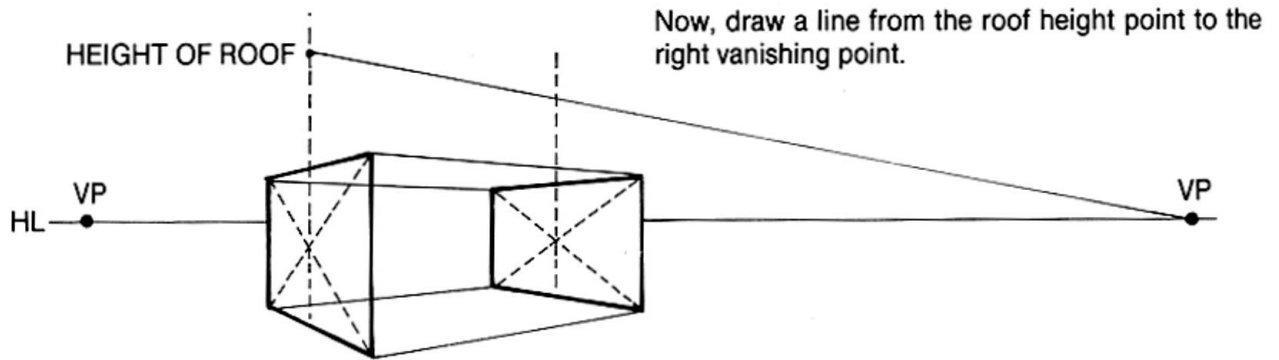

4)

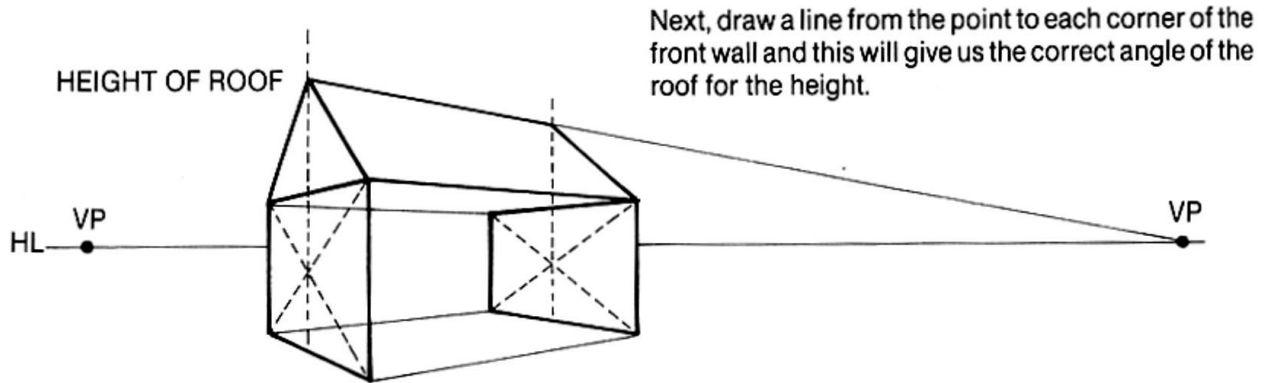

The point where the line for the top of the roof crosses the back vertical center line marks the point and pitch of the roof at the back of the house.

5) Now you will add the following to begin the final detailing of the base structure:

- **Windows, Siding, Door, & Pathway**

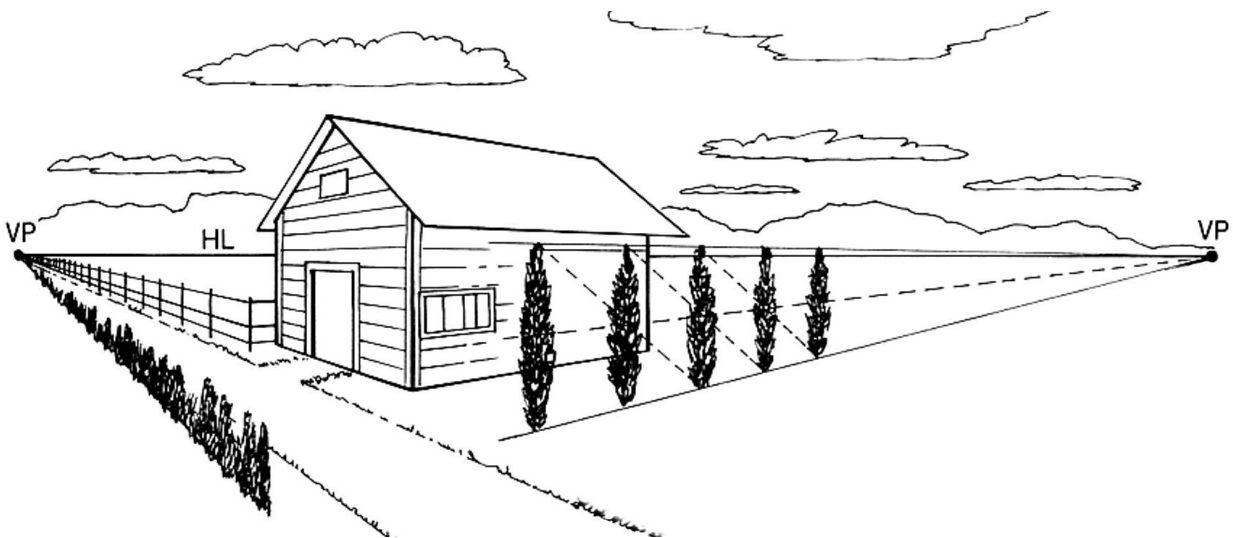

- 6) Use the following close up reference to see how the basic detail elements still follow the same exact rules of 2-point perspective. Your lines will either go straight up and down, or run to one of the vanishing points. You should be able to figure this out by now.

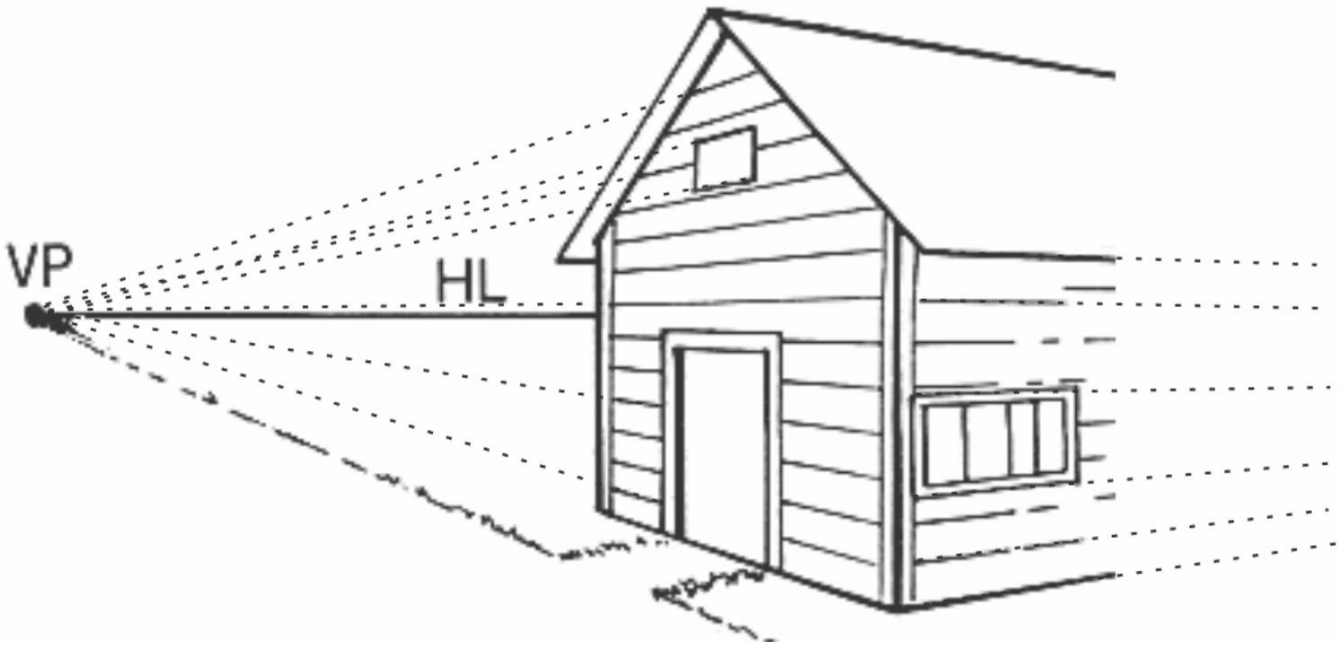

- 7) Once you have made the house similar to the example, follow the steps to create an accurate line of trees or bushes that recede into the distance appropriately.

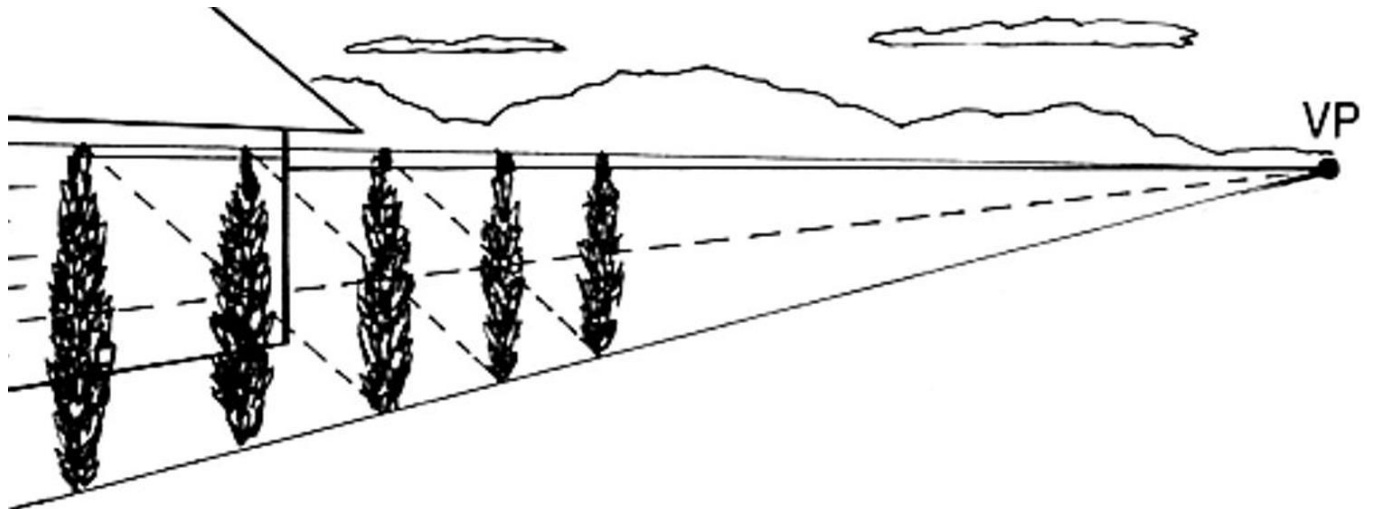

continued

8)

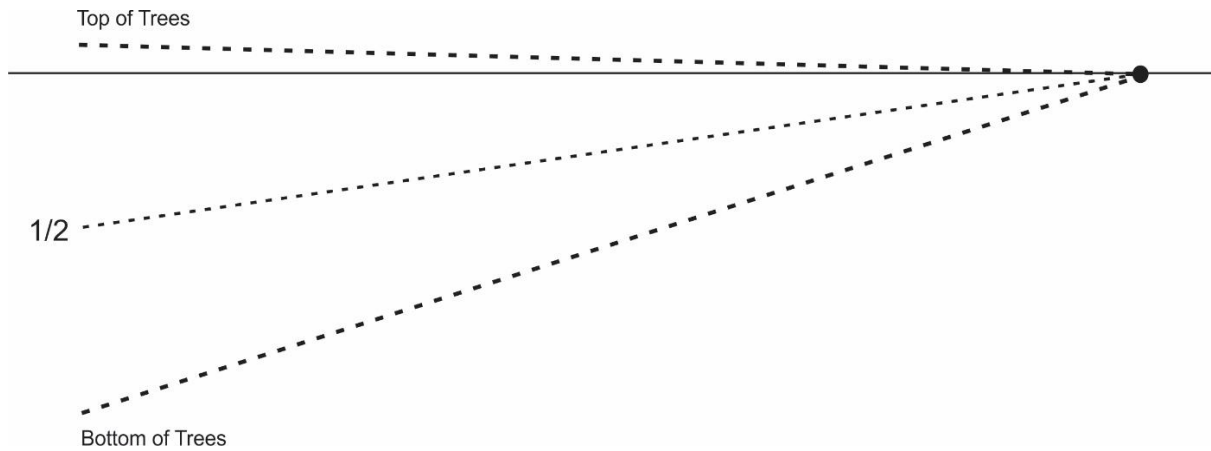

Use your ruler to make a light guideline line that will indicate the tops of your trees. Do the same thing to indicate where the bottom of your trees will be. It will look similar to a sideways "V". Then find the approximate MIDDLE or halfway point between the two lines, and lightly draw a guideline as shown above.

9)

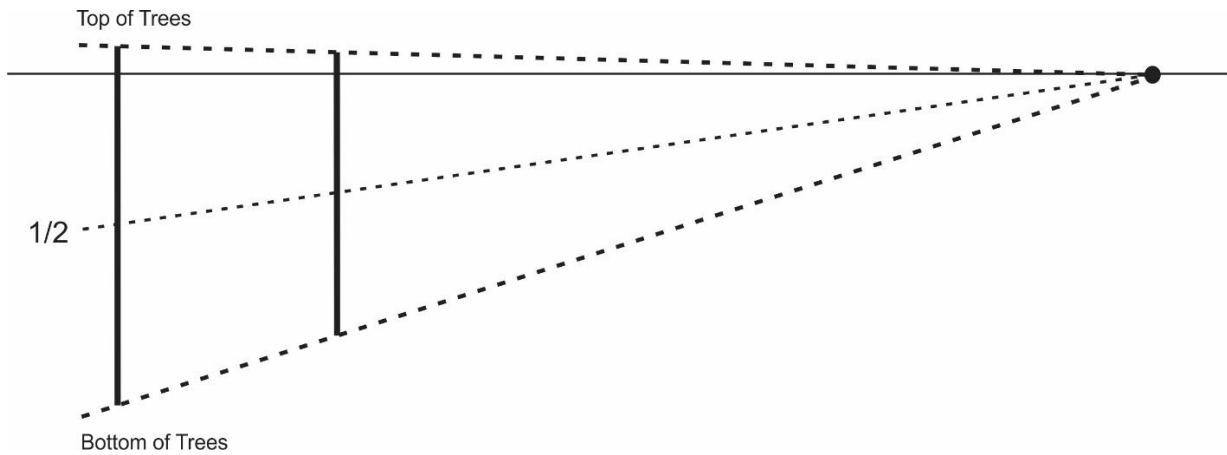

Make a vertical line between the guides to indicate your first tree. Choose a place for the 2nd tree as well

10)

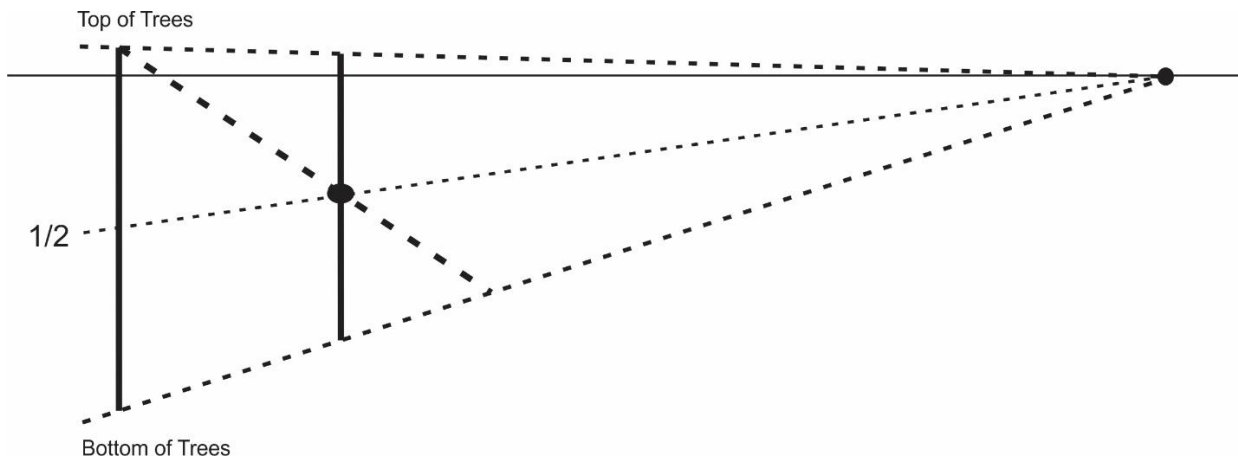

Use your ruler to make a light guideline from the top of the first mark, through the middle of the 2nd

11)

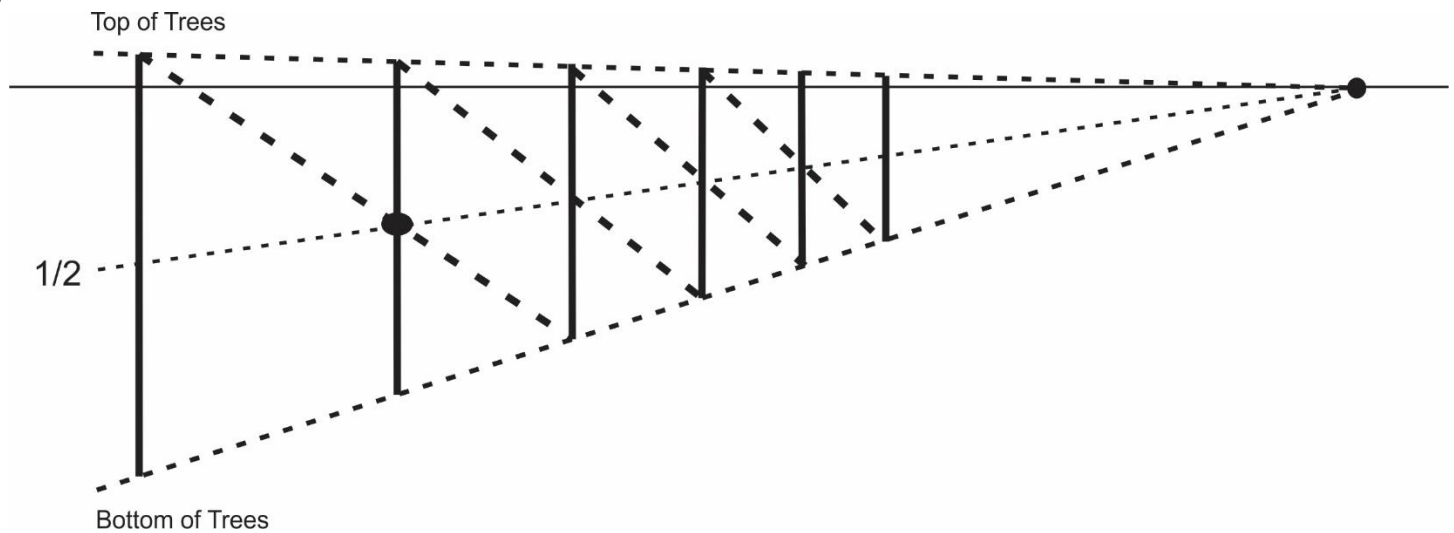

Draw another line straight up to indicate your new tree. Repeat the process of step 10 over and over. You will see your tree line disappearing off into the distance in correct perspective.

12)

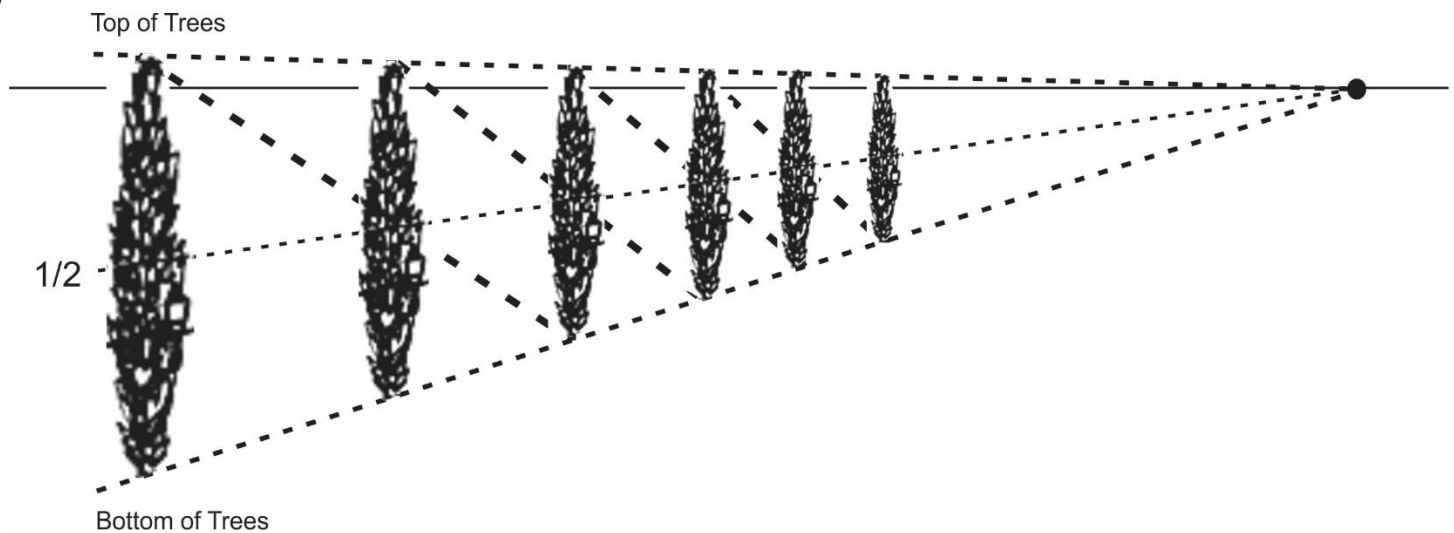

Begin to fill in your tree markers with actual tree shapes! These can be as complex or simple as you wish, but they should still be drawn with appropriate care.

13) Look at the overall scene below. Your drawing should be similar to it. It doesn't have to be exact, just contain the elements listed in the evaluation.

14) Invent one object to draw in Two Pt-Perspective in the remaining space

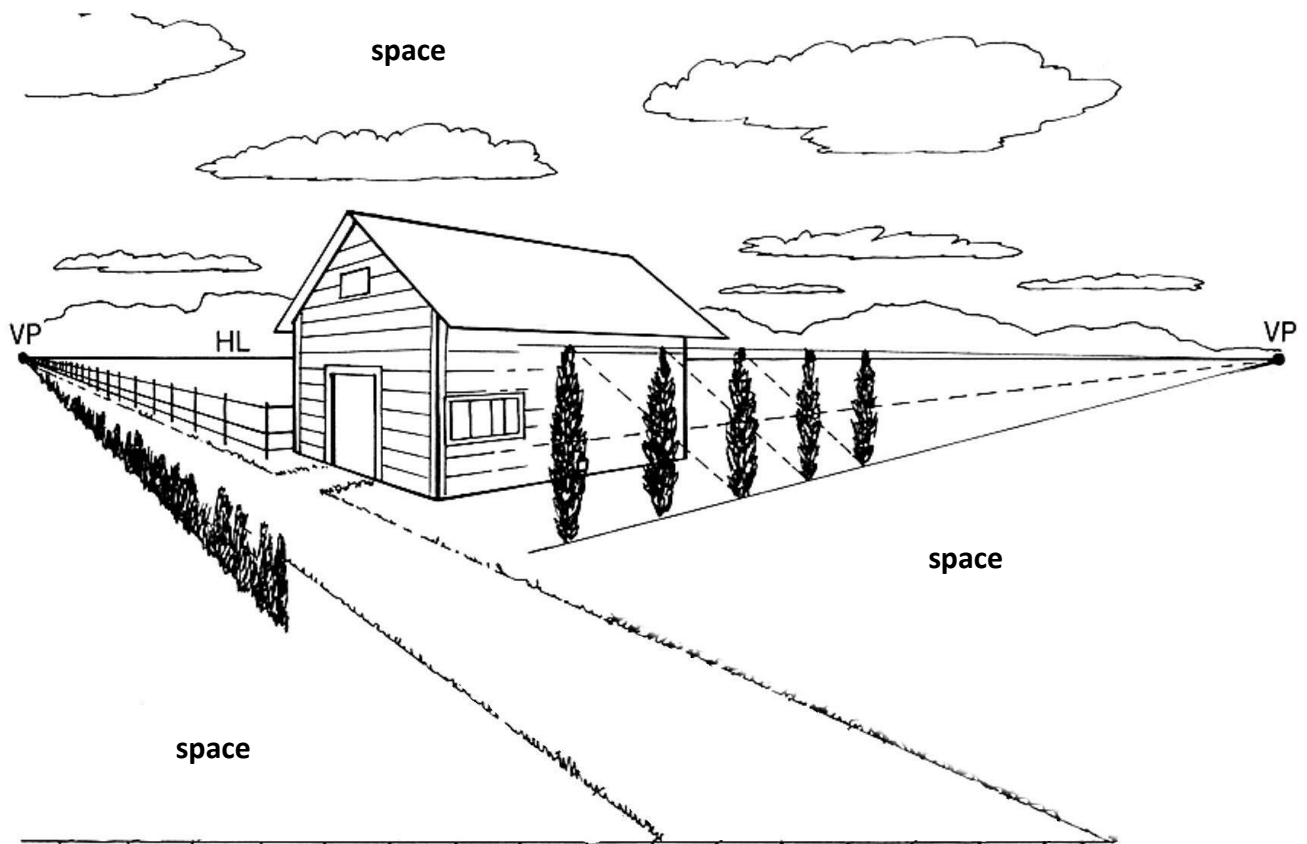

Evaluation: 35 pts summative

- 1) Draw the house and roof angles correctly
- 2) At least two windows and a door
- 3) A path outside of the house connected by a walkway
- 4) Bricks or siding on the house
- 5) Minimum of Five (5) trees or bushes using the correct formula as shown
- 6) A fenceline wherever you want, also using the same formula
- 7) Create at least one new object you invent in the remaining space